

User Manual

Upper Arm Digital Blood Pressure Monitor

CK-A139

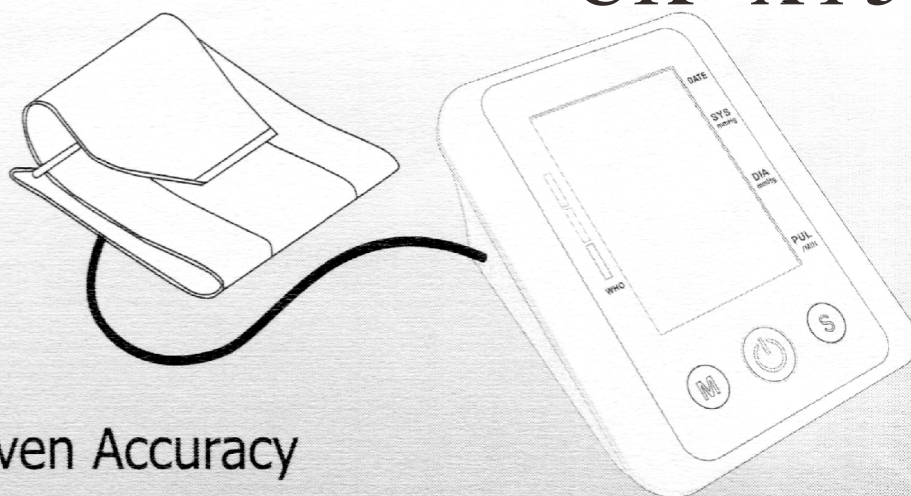

- Clinically Proven Accuracy
- One Touch Operation
- Large LCD Display
- 2×99 Memories
- 2 Users
- Pressure Rating Indicator
- Voice Broadcast(option)
- Time & Date Display
- BP & Pulse Measurement

Product Description	2
Taking a measurement	3
Introduction	4
What you should know about blood pressure	5
Blood Pressure Standard	5
Precautions to Ensure Safe, Reliable Operation	7
Inserting Batteries	8
Setting	9

Positioning the Pressure Cuff	10
Position for Blood Pressure Measurement	11
Measuring Your Blood Pressure	13
Memory Function	14
Care and Maintenance	15
Calibration	15
Error Message	16
Troubleshooting	17
Specifications	18

QUICK GUIDE ON SOME SETTINGS FROM CK-A139 DEVICE

How to turn the Speaker OFF:

1. Press Start/stop button to turn on or off the device at anytime
2. While the device is turned off, Press SET and hold for 5 seconds
3. Use MEM button to select the user you want to configure, use SET to acknowledge
4. Use MEM to select the year and use SET to acknowledge until you get to SP ON/Off Use MEM to select either you want the Speaker on or off and use SET to acknowledge
5. Use the same setting to set Alarm for same time monitoring everyday. Alarm 1 and 2

How to Check stored Memories

1. While the device is turned off Press MEM button
2. Keep pressing MEM button to navigate each reading until 99 Memories.

To Delete previous reading stored

1. While the device is turned off Press MEM button
2. Keep pressing MEM button to navigate each reading until 99 Memories.
3. Press and hold SET Button until 'DEL' shows at the top screen then Press MEM button to delete

Note:

USB Cable included is for Power Supply Only

Can be used with Mobile charger, Laptop USB port, Power bank (not included)

Main body

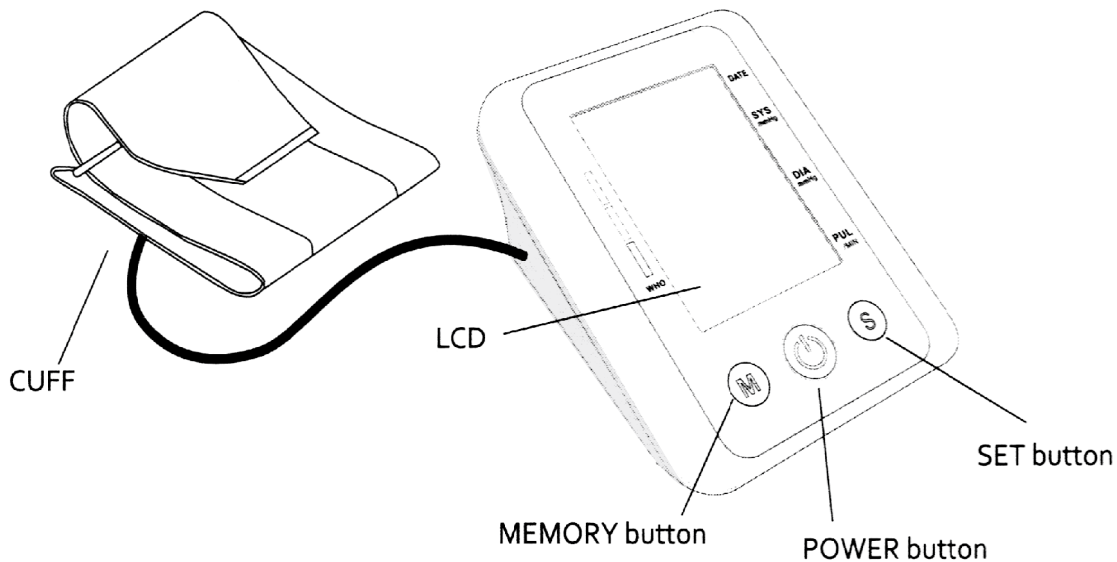

Batteries

- Alkaline batteries (LR6 SIZE AAA) can be used for approximately 250 measurements (approximately 3 months, 3 times a day), at an ambient temperature of 23 °C (73.4 °F) at 170mmHg for an upper arm circumference of 22-32 cm.
(The batteries included are not guaranteed for the full life of brand new alkaline batteries as specified.)
- Battery life may be shortened if the ambient temperature is low.
- The number of measurements that can be taken with a set of batteries will be drastically reduced if batteries other than alkaline batteries are used. Use only alkaline batteries.
- Please replace the batteries at the same time and ensure that they are of the same type and make.

USB Cable: DC 6V Adaptor or Equivalent can be used as power source.

Taking a measurement

1. Fasten the cuff on the palm side. Make sure it is not too tight. The cuff's lower edge should be approximately one inch from the crook of the arm.

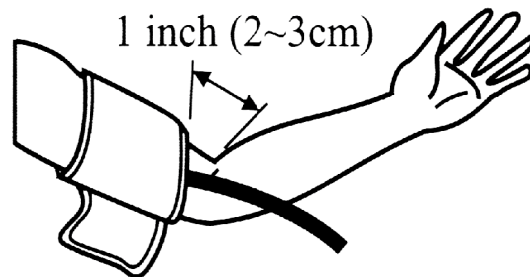

2. Make sure the cuff is at heart level.

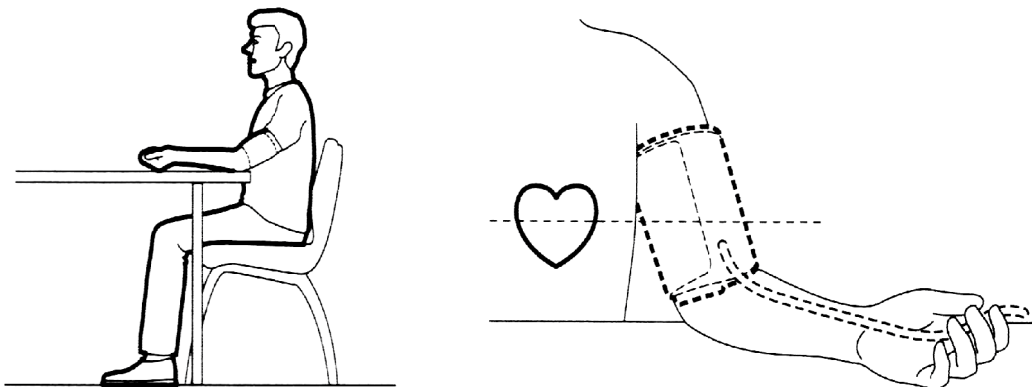

3. Press the USER button (or the SET button) to choose the user number for memory storage (the default setting is Number 1) (option).

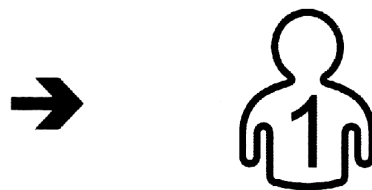

4. At the end of the measurement, a beep sounds and the reading is displayed:

Upper (systolic) value
Lower (diastolic) value
Pulse

Caution

1. Consult your physician to verify your blood pressure range before obtaining them at home with this unit.
2. If the cuff causes any discomfort during measurement, press the ON/OFF button to turn off the unit immediately.
3. Take off the arm cuff if the pressure is over 300mmHg and the cuff does not deflate automatically.

To be able to utilize all advantages of the blood pressure monitor to the fullest, please carefully read these instructions before using the device.

Introduction

Thank you for purchasing the Upper Arm Digital Blood Pressure Monitor .CK-A139 is a blood pressure monitor that has been developed for easy and accurate blood pressure measurements for the upper arm. The measuring accuracy of CK-A139 was tested at the time of manufacture and was proven by clinical research in accordance with AAMI/ANSI-SP10.

Blood pressure measurements obtained with this unit are equivalent to those obtained by a trained person using the cuff/stethoscope auscultation method, within the limits prescribed by the American National Standard, electronic, or automated sphygmomanometers.

Measuring your own blood pressure is an important way of monitoring your health. High blood pressure (hypertension) is a major health problem which can be treated effectively once detected. Measuring your blood pressure between doctor visits on a regular basis in the comfort of your home, and keeping a record of the measurements, will help you monitor any significant changes in your blood pressure. Keeping an accurate record of your blood pressure will help your doctor diagnose and possibly prevent any health problems in the future.

Introduction

Blood pressure constantly changes throughout the day. It rises sharply in the early morning and declines during the late morning. Blood pressure rises again in the afternoon and finally drops to a low level at night. Also, it may vary in a short period of time. Therefore, readings from successive measurements can fluctuate.

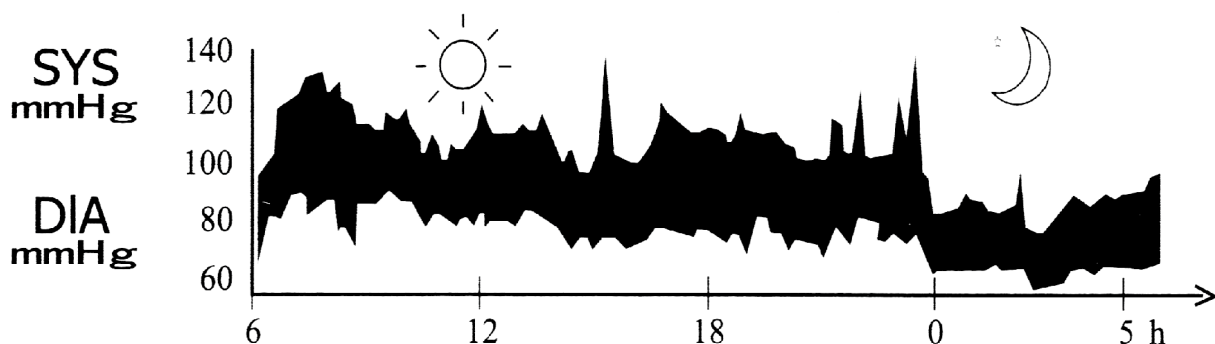

Blood pressure readings from a healthy 31-year old male, measured at 5-minute intervals.

Blood pressure measured in a doctor's office only provides a momentary value. Repeated measurements at home better reflect one's actual blood pressure values under everyday conditions.

Moreover, many people have a different blood pressure when they measure at home, because they tend to be more relaxed than when in

the doctor's office. Regular blood pressure measurements taken at home can provide your doctor with valuable information on your normal blood pressure values under actual “everyday” conditions.

Blood Pressure Standard

The World Health Organization (WHO) has set up the following standard blood pressure values when measured at resting pulse:

Blood Pressure (mmHg)	Normal Values	Mild Hypertension	Severe Hypertension
SYS = systole = upper value	up to 140	140-180	over 180
DIA = diastole = lower value	up to 90	90-110	over 110

CAUTIONS:

- * Keep product and batteries away from children.
- * People suffering from cardiac arrhythmia, vascular constriction, arteriosclerosis in extremities, diabetes or users of cardiac pacemakers should consult their doctor before measuring their blood pressure themselves, since deviations in blood pressure values may occur in such cases.
- * If you are under medical treatment or taking any medication, please consult your doctor first.
- * The use of this blood pressure monitor is not intended as a substitute for consultation with your doctor.

Precautions to Ensure Safe, Reliable Operation

- * Avoid eating , smoking as well as all forms of exertion directly before the measurement. All these factors influence the measurement result.
- * Try and find time to relax by sitting in an armchair in a quiet atmosphere for at least 5 minutes before the measurement.
- * Remove any garment that fits closely to your wrist.
- * Measure always on the same arm (normally left).
- * Attempt to carry out the measurements regularly at the same time of day, since the blood-pressure changes during the course of the day . The ideal time to measure your blood pressure is in the morning immediately after waking up, while you are still relatively calm. If this is not possible, try to take your blood pressure prior to breakfast, before you become active.

Inserting Batteries

1. Pull the battery cover from the unit as the figure shows.
2. Insert batteries into the battery compartment matching correct polarities “ + ” and “ - ”.
3. Put the battery cover back into place on the main body until it clicks into place.

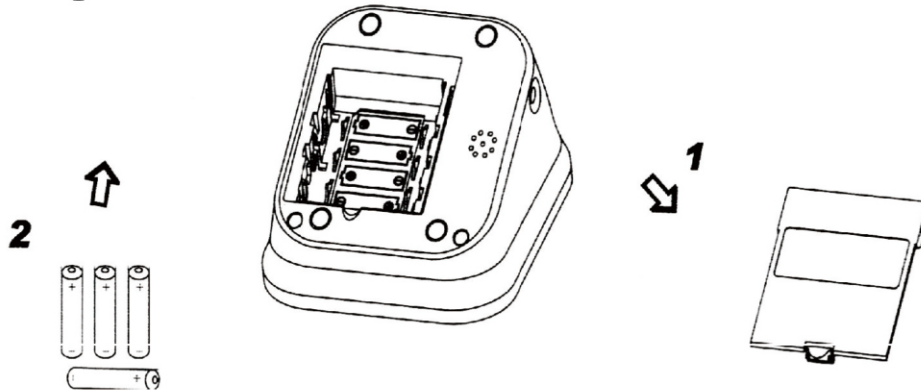

Note:

Change the batteries when the battery symbol  is displayed on the top left corner of the display or when no data is displayed even the ON/OFF button is pressed.

Do not mix old and new batteries.

Caution:

Do not throw batteries into a fire. Doing so may result in an accident or explosion.

Using USB Cable:

DC 6V Adaptor can be used to power device.

Source of power while using USB cable: Laptop, mobile phone chargers, Power pack.

Note:





·USB Cable included is for Power Supply Only

Caution: Never plug device directly to 220V electricity. Equivalent DC6V Adaptor is always needed.

Setting

Having inserted the batteries, set the time and date so that any future stored measurements are saved in the memory with the correct time and date. You may also take measurements without fast setting the time and date.

1. Set user

Press the USER button or press the SET button a few seconds, a displayed  will flash on and off. Press the MEMORY button to adjust  or . The default user is .

2. Set the year

Press the SET button, a displayed year will flash on and off. Press the MEMORY button to adjust year. Pressing this button for long, the digit will increase quickly.

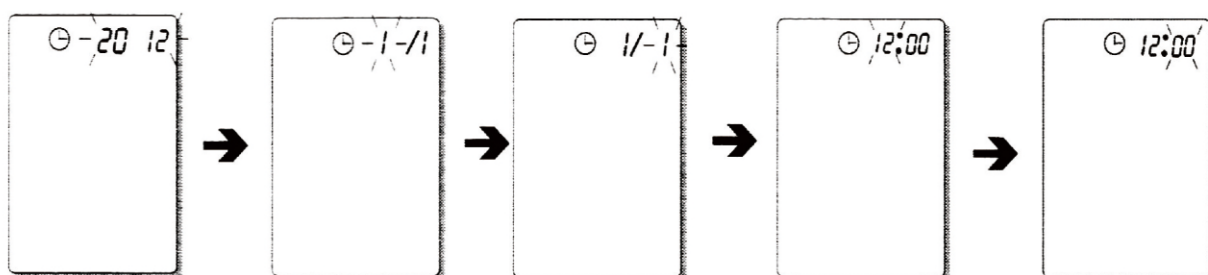

3. Set date & hour

Then press the SET button again, the month digits will appear and flash. Again, repeat pressing MEMORY button to adjust the month. With pressing the SET button, the date, hour and minute digits will flash, repeat adjusting them by pushing the MEMORY button.

4. When you finish the setting you can press the SET button to exit the setting and turn off the device as well.

Positioning the Pressure Cuff

CAUTION:

Do not use the unit for any purpose other than measuring blood pressure. Also, do not use the unit in conjunction with other devices. Improper use may cause a malfunction or personal injury

1. Fasten the cuff on your left upper arm. It will be best to use a bare arm.

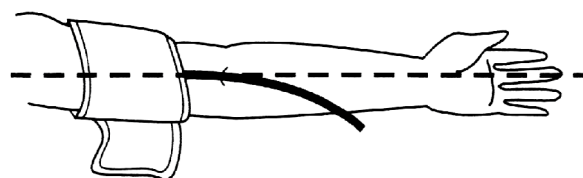

2. Make sure the cuff is not too tight. The cuff's lower edge should be approximately one inch from the crook of the arm.

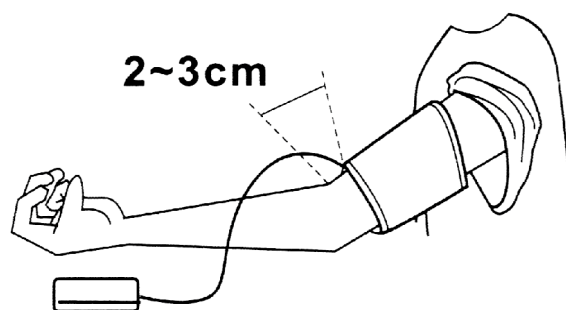

3. The unit can be used on either the left or the right wrist. When taking blood pressure measurements using the right hand position the cuff as it shows.

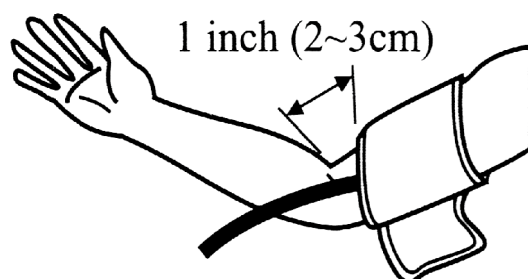

However, as it is said that there can be a difference of up to 10mmHg between the left and the right arms, please ensure that you always use the same arm. Always rest for about 3 to 5 minutes before taking measurements. Press ON/OFF button to start a measurement. The cuff will inflate automatically and then deflate when the measurement is completed.

Position for Blood Pressure Measurement

When measuring your blood pressure at your arm, the pressure cuff must be at heart level to ensure consistent, accurate readings.

Taking measurements while sitting down.

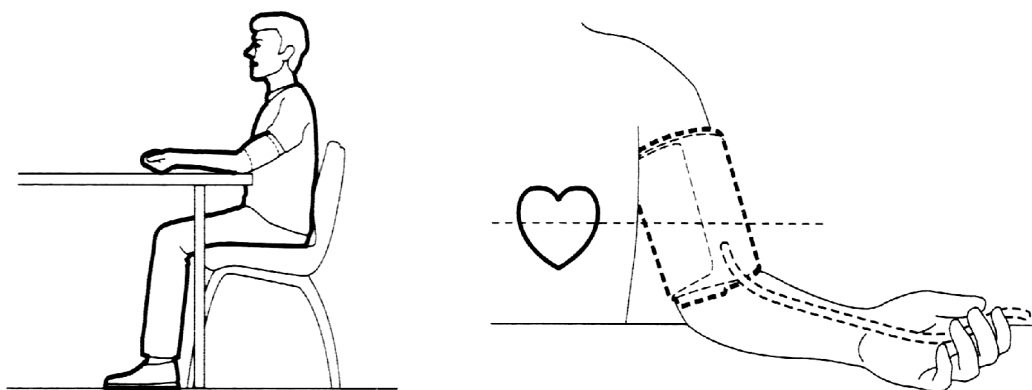

CAUTION:

- * Do not use close to cellular phones or other devices which emit electromagnetic waves. Doing so may result in malfunction.
- * Do not move your body, your arm, or your fingers while taking measurements.

Measuring Your Blood Pressure

Relax during measurement.

1. Fasten the cuff.
2. Press the ON/OFF button.
 - * Everything on the display will be shown for approx. 1 second.
 - * The cuff will begin to inflate automatically.
 - * Inflation stops automatically and the measurement is started.
 - * Once your pulse rate is detected, the  mark will flash on the display with sounds.
3. Blood pressure values together with pulse rate are displayed when the measurement is completed with sound.
 - * The air in the pressure cuff is released automatically.
 - * The displayed pulse rate indicates the number of heartbeats per minute as calculated from the number of heartbeats recorded during the measurement.
4. Press the ON/OFF button to switch off the unit.
 - * If you forget to switch the unit off, it will do so automatically after approx. 2×99 seconds.

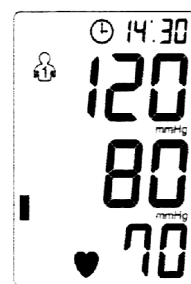

Memory Function

The blood pressure monitor can store 99 readings for each user (2 users). Once the memory is full, the oldest values will be overwritten. The CK-A139 model features also an average function to display the average data of the latest three readings.

View of Average Readings (AVG)

The monitor can store the average values (AVG) of the latest three readings. Under power-off mode or after you finish a measurement, press the MEMORY button, the AVG reading is displayed.

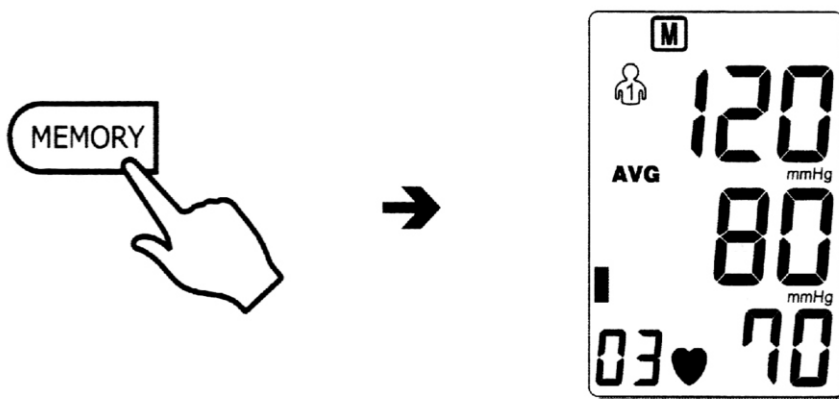

Recalling Stored Readings

1. Press the MEMORY button the AVG reading will be displayed firstly.
2. Continue to press the MEMORY button, the most recent stored reading will be displayed (eg. the first memory). The date and time will alternate to be displayed.

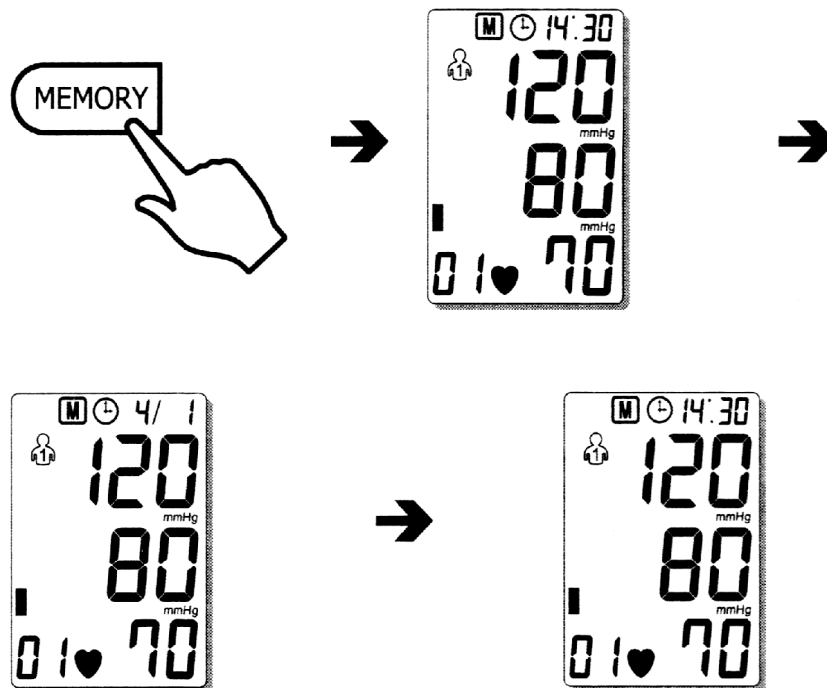

3. Repeatedly pressing the MEMORY button will call up all stored readings one by one. Continuously pressing the MEMORY button will scroll through all stored readings.

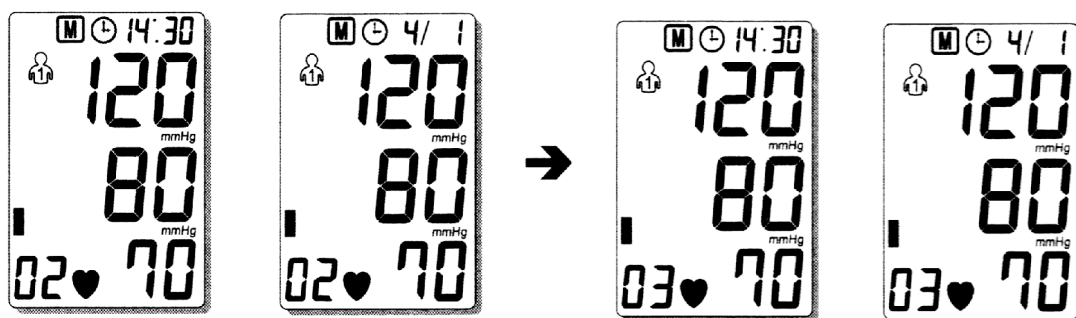

Note:

The memory can not be cleared unless you cut the power off.

Care and Maintenance

- * Do not expose the BP monitor to extreme temperature, moisture, dust or direct sunlight.
- * The cuff contains a sensitive airtight bulb. Treat it with care and avoid any stress by torsion or kinking.
- * Clean the BP monitor with a soft cloth. Do not use fuel, thinner or other solvent. Remove specks on the cuff carefully with a wet cloth and soap water
- * Do not wash the cuff.
- * Do not drop the BP monitor or treat it with force.
- * Do not try to open the BP monitor . This will make the factory calibration invalid.
- * If the unit has been stored at temperatures below 0 °C(32°F), leave it in a warm place for about 15 minutes before using it. Otherwise, the cuff may not inflate properly.
- * Do not attempt to disassemble the unit.
- * Do not crush the cuff.
- * When the unit will not be used for a long time (30 days or more), be sure to remove the batteries.

Calibration

This product has been calibrated at the time of manufacture. If used according to the use instructions, periodic recalibration is not required. If at any time, you question the measuring accuracy, please contact an authorized Service Center.

Error Message

Message	Correction
Er 1	The pressure measured was lower than 20mmHg. Please measure again.
Er 2	The pressure can not be measured due to signal noise. Please measure again.
Er 3	The pressure measured was higher than 300mmHg. Please measure again.
Er P	Pumping error. Please check cuff and try again.
HI	The pumping pressure is higher than 300mmHg. Please measure again.
 or not display	Low battery. Please check and replace the 4 batteries if necessary.

Troubleshooting

Problem	Reason	Solution
Readings from repeated measurements differ significantly.	Blood pressure is a fluctuating value. For healthy adults, deviations of 10 to 20 mmHg are possible.	none
	Cuff is not properly fitted.	Ensure that the cuff is fitted as follows: --on the palm side of your arm. -- approximately one inch from the crook of the arm.
	Talking, coughing, laughing, moving etc. when measuring will influence the reading	While measuring, relax, keep still, do not move or speak.
The systolic pressure value or diastolic pressure value is high or low.	You moved your hand or body or you spoke during the measurement.	Do not move or speak.

Specifications

Model	CK-A139
Display System	Liquid Crystal Display
Measuring Method	Oscillometric method
Measuring Range	Blood Pressure: (0~280)mmHg Pulse Rate: (40~199)pulse/minute
Accuracy	Pressure: within ± 3 mmHg Pulse Rate: within $\pm 5\%$ of readings
Auto Power-Off	60 secs. no any operation
Battery Life	Around 250 operations
Operation Temperature and Humidity	+5°C ~+40°C , $\leq 30\% \sim 85\%$ R.H, 70kPa~106kPa
Transport and Storage Conditions	-20°C ~+55°C , $\leq 15\% \sim 90\%$ R.H, 70kPa~106kPa
Arm Circumference Measurement Range	Approx. 22 to 32 cm
Power Source	DC6V; "AAA" type battery $\times 4$ (LR6)
Dimensions	125*147*61mm
Weight	Around 450g (not including batteries)
Clinical Accuracy	According to AAMI-SP10 <5 mmHg systematic offset < 8 mmHg standard deviation

Specifications are subject to change for improvement without notice.

If device is not used within specified temperature and humidity ranges the technical accuracy can not be ensured.

Guarantee

We grant 2 years guarantee on the product commencing on the date of purchase. Within the guarantee period we will eliminate, free of charge, any defects in the appliance resulting from faults in materials or workmanship, either by repairing or replacing the complete appliance as we may choose.

Disposal note

The disposal of batteries is regulated. Spent batteries are collected at collection points provided by battery dealers and the communities. Disposal of the blood pressure monitor as prescribed, i.e., at a collection point for electrical scrap.

For online pdf manual visit
spinegear.co.uk

<https://Spinegear.co.uk>

Easycheap ltd
No 1 Birmingham drive, Kingsbrook HP22 7AG
www.spinegear.co.uk

Notified Body: SGS Belgium NV
Noorderlaan 87, BE-2030 Antwerpen, Belgium



Share Info Consultant Service LLC Repräsentanzbüro
Heerdter Lohweg 8340549 Düsseldorf, Nordrhein-Westfalen,
Deutschland